

### VÁLVULA ESFERA – FIG. 951

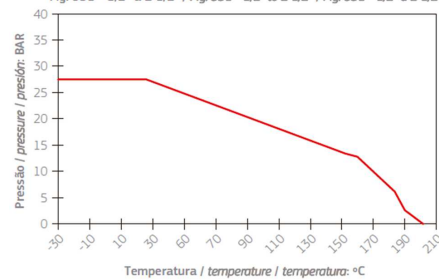

MEDIDAS		DIMENSÕES			
NPS*	DN**	A	B	C	ØD
1/2"	15	60,0	45,0	99,0	9,1
3/4"	20	66,0	46,0	99,0	12,7
1"	25	79,0	55,0	112,0	17,0
1 1/4"	32	94,0	73,0	134,0	24,0
1 1/2"	40	103,0	78,0	134,0	30,5
2"	50	123,0	89,0	176,0	38,0
2 1/2"	65	143,0	98,0	176,0	49,0

Fig. 951 - 1/2" a 2 1/2" / Fig. 951 - 1/2" to 2 1/2" / Fig. 951 - 1/2" a 2 1/2"



\* NPS = Tamanho nominal da tubulação.

\*\* DN = Diâmetro nominal.

Construção baseada na norma NBR 14788.

Extremidades de acordo com a norma ISO 7.1 (BSP) ou ANSI B 1.20.1 (NPT).

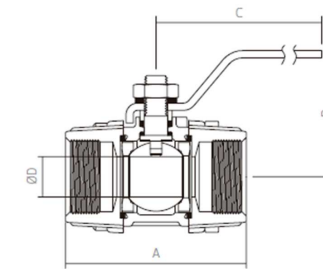
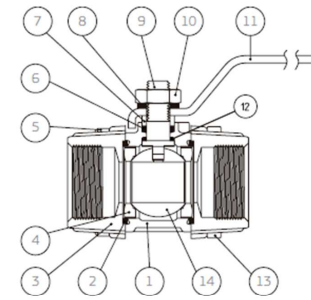

POS.	DENOMINAÇÃO designación designación	MATERIAL material materiales	ABNT	ASTM
1	Corpo body cuerpo	Bronze bronce bronce	NBR631 4/ C83600	B-62/ C83600
2	Junta gasket guarnición	PTFE	-	-
3	Tampa Bonnet Boneto	Bronze bronce bronce	NBR631 4/ C83600	B-62/ C83600
4	Sede Seat Asiento	PTFE	-	-
5	Parafuso alien bolts tornillo	Aço stainless acero	-	-
6	Gaxeta packing empaqué	PTFE	-	-
7	Bucha gaxeta packing gland prensa empaqué	Aço inox stainless steel acero inox	-	inox 304
8	Arruela pressão pressure washer presión Arandela	Aço stainless acero	NBR600 6	SAE1070
9	Haste stem vástago	Aço inox stainless steel acero inox	NBR560 1/ 304	CF 8 A- 743
10	Porca sextavada nut tuerca	Aço bicromatizad o dichromated steel acero bicromatiza do	-	-
11	Cabo handle mango	Aço stainless acero	SAE 1020 pintado	
12	Arruela washer arandela	PTFE	-	-
13	Porca sextavada nut tuerca	Aço bicromatizad o dichromated steel acero bicromatiza do	-	-
14	Esfera ball bola	Aço inox stainless steel acero inox	NBR560 1/ 304	A 276/304